

# PORTABASE™ Trench Mount

➤ Assembly & Operation Guide

## > Contents

### Correct Operation 4

Intended Use  
Inspection Prior to Initial Operation  
Inspection Before Starting Work  
Maximum Capacity  
Temperature Range  
Notes for Correct Operation  
Warning  
Allowable Rotation

### Fall Protection Applications 7

Fall Protection  
Additional Notes for Correct Operation  
Warning

### Inspection & Maintenance 12

Regular Inspections  
Maintenance & Repair  
Storage & Transportation

### Fitting Instructions 13

### Dimensions 14

### Notes 15

### Quality & Safety 16

Regulations, Standards & Directives  
Accreditations  
Conformité Européenne [CE] & UK Conformity Assessed [UKCA]  
The Queen's Award for Enterprise  
Testing  
Language  
Product IPR

### Product Labelling 18

### Inspection Record 19



# Lightweight. Portable. **Safe.**

Please read the following instructions and guidance notes carefully, before using or operating the system. They contain important information about how to handle and use the system in a safe and efficient way, avoiding danger, reducing repair costs and downtime, and increasing the reliability and lifespan of the system.

They apply for:

- > Operation, including preparation, troubleshooting during operation and cleaning
- > Maintenance, inspection and repair
- > Transportation

It is the responsibility of the end user to adhere to the Health & Safety and accident prevention standards and legislation valid in their respective countries and any regions in which the system is being used. It is also incumbent on the user or competent person to ensure that anyone working with the equipment has the necessary medical and physical capabilities. A rescue plan also needs to be in place in the event of an emergency that could occur during the work. This document should form part of the overriding Risk Assessment and Method Statement required for each lift.

## Intended Use

This product is designed, tested and intended to be used for the lifting of goods, the lifting of personnel or for providing a safety anchor for the prevention of falls as part of a personal fall protection system. (PFAS). The use of our products for these multiple applications is consistent with the products design, notwithstanding pre-user inspections and mandatory inspections by a competent or qualified person, determined by local regulations.

This product forms one part of a lifting system, the other part being a REID Lifting Davit. Before using the equipment, both Assembly & Operation Guides must be read.

**Lifting of Goods:** Each product will be marked with a Working Load Limit (WLL). The WLL is specifically intended as a maximum limit for the lifting of goods, materials and equipment and includes safety factors.

**Lifting of Personnel:** For the lifting of personnel REID Lifting will reduce the WLL by half, thereby increasing the safety factor of the product. As for lifting goods, materials and equipment, the lowest rated element of the product always takes precedent. Associated equipment used for lifting personnel must be rated accordingly. It is the employers' responsibility to ensure this is the case. For example, a winch must be personnel rated and where necessary, meet applicable standards and regulations for the country of use.

**Fall Protection Anchor:** In most cases (subject to labelling and instructions for use for specific products confirming this) REID lifting products are tested and meet the requirements of fall protection standards and regulations, including EN795:2012 as referenced in our Instructions for Use. The WLL on the product is of no relevance to fall protection standards and requirements and the user should refer to the specific sections of the instructions for use, for detailed information. For example; EN795 requires that anchors that form part of a personal fall protection system are capable of withstanding a minimum 12kN static load for a single user and a further 1kN for each additional user. Additionally, fall protection systems are required to pass a series of dynamic performance tests. REID Lifting products will, where applicable be marked with the rating for fall protection. Safety factors will be higher than those for lifting and forces will be limited by the use of personal fall protection equipment, including load limiting devices such as shock absorbers or self-retracting lifelines that reduce impact forces, typically to a maximum of 6kN per user as required by law.

Note: some jurisdictions may not allow the same equipment to be used for lifting of materials and as a component of a PFAS. Some employers may also prefer to keep such equipment distinctly separate. If this is the case, we would recommend that the equipment is labelled accordingly Check your local regulations before putting equipment to use and designate accordingly.

It is expected that all users of this product have the necessary medical and physical capabilities, are fully trained and deemed competent in its safe assembly and use. We would remind users of the requirement to ensure that work is properly planned, risk assessments carried out and as required, method statements for carrying out work provided.

Where required the owner/user of the equipment should ensure that a qualified person has been consulted in respect of the need for structural validation, for example (but not limited to); calculating imposed loads for the safety of ground, floor or roof structures during lifting operations.

## Inspection Prior to Initial Operation

Each product must be inspected prior to initial operation by a competent person to ensure that the structure is safe and that it has not been damaged by incorrect assembly, transport or storage.

## Inspection Before Starting Work

Before starting work, the product assembly and all load-bearing components should be checked for visual defects as per the inspection checklist on page 12.

## Maximum Capacity

**Goods Lifting:** This product is designed to lift and lower loads up to its rated capacity. Do not exceed the capacity indicated on the system.

**Personnel Lifting:** When lifting people, the overall load limit is reduced by half to provide an increased safety factor. The maximum capacity permitted by the personnel winch/accessory used in conjunction with the product also needs to be considered.

If you are unsure about the system, consult the serial labels information on page 19 or consult your supplier.

PORTABASE Maximum Capacity [kg]				
Part Code	Description	Maximum Radius	Goods Lifting	Personnel Lifting
PBTM00001	Trench Mount	1200mm	500kg*	250kg*

\*90° pivot angle

For fall protection applications see page 7.

## Temperature Range

This product can be operated in ambient dry temperatures between –20°C and +55°C (-4°F and 131°F). Consult your supplier in case of extreme working conditions. If used in sub-zero and wet conditions, fall arrest appliances characteristics may change.

## Notes for Correct Operation

- Read in conjunction with the instructions for use of your chosen REID Lifting Davit
- We recommend the use of load-sensing or overload protection devices on all lifts
- The risk assessment and method statement must consider any factors that might apply additional loading to the system during lifting operations
- Suitable, appropriately rated winches, hoists and bracket plates must be used for all applications
- Take care when transporting and storing the system to avoid damage
- Assemble only as instructed (ensure all bolts and pins are present and fitted correctly as per instructions)
- We recommend that appropriate PPE are worn when using the equipment
- Attach the hoist to the dedicated lifting points only, making sure it is attached in a way that does not expose the user to danger by the hoist, chain or load
- Do not allow the load to swing
- To avoid side pull, lowering and lifting should only be carried out when the load chain forms a straight and vertical line between the load and lifting attachment point.

## Warning

- The equipment should not be used outside of its limitations, or for any purpose other than that for which it is intended
- Do not lift or transport loads while personnel are in the danger zone
- Do not allow personnel to pass under a suspended load
- Never leave a suspended load unattended
- Be aware of hazards when setting up/folding down, such as trapping fingers in rotating parts
- Be aware of any adverse weather conditions such as strong or gusty winds which could impose additional horizontal loads and affect the stability of the structure. Stop using if weather is impacting on lifting, and either disassemble the system or tie it to a rigid structure to ensure it can't overturn
- Don't allow the load to hit the system
- Under no circumstances should the product be moved under load
- Do not lift a load outside the permissible operating radius

## Allowable Rotation

The allowable operating area for the Trench Mount is dependent on the application in which it is being used.

For goods lifting up to 500kg, personnel up to 250kg the allowable rotation is 180° in front of the socket, for fall arrest applications the allowable area is 45° each side from the centre of the base [1].

Outside of the 180° angle, in the remaining 180° the system is suitable for 200kg goods lifting & 100kg personnel lifting.

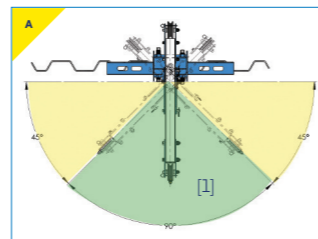

## Fall Protection

**This section must not be read in isolation from all other sections of this manual. Read the whole manual before using this product.**

**Fall arrest:** This product is tested and conforms to the requirements of EN795:2012 Personal Fall Protection Equipment – Anchor Devices subject to the configuration of the product and the Davit being used.

When being used for fall arrest purposes, the operator must use a body harness and a shock absorber that complies with the relevant national standards and regulations and that limits the maximum allowed force (m.a.f.) to 6kN.

Each personnel lift must be properly planned, and all weights clearly known along with a clear understanding of the WLL and constraints of all personal fall arrest system components.

If unsure about your system consult serial labels, information filled in on page 19 or consult your supplier. Custom versions of the system are available tailored to specific lifting needs. These versions are designated with a 'C' at the end the product number on the serial label attached to each product.

## Additional Notes for Correct Operation & Warnings

- Always carry out pre-use checks before using this equipment.
- Never walk away from the footprint of the product or move outside designated safe zones whilst connected to it where there is a risk of a fall.
- When using the product as a fall arrest anchor ensure there is adequate fall clearance when working at height. A competent person should calculate this, taking in to account all of the components of the personal fall arrest system.
- Always consider the potential effects of sharp edges, chemical reagents, electrical conductivity, cutting, abrasion, climatic exposure on all components of the fall protection system, and the effect of offset forces as a result of pendulum falls.
- Do not use a davit with a larger radius than permissible.
- Ensure the structure on which the product is mounted is level.
- If the product has been subjected to a fall arrest or impact force it must be immediately removed from service.
- The substrate of the structure on which the product is placed must be able to withstand all the forces transmitted by the system when generating a maximum moment of 7.2kN.m (service load 6kN) Safety factors must be applied.
- Always make sure all 4 studs have been torqued to the correct settings before use.
- Check the internal side of the socket is in contact with the top of the trench sheet or box before use.
- Never exceed the number of allowable users.
- Never adjust the product whilst a person is attached to it.
- Only use designated anchor points for the attachment of fall protection devices.
- Ensure that any fall protection system components being used are compatible and meet the requirements of applicable standards.
- When using this product ensure that there is a rescue plan prior to starting work and ensure that users are trained in the correct execution of the plan and have all necessary rescue equipment to hand.
- Where required by regulation, each installation must be approved by a qualified person.



The system is not suitable for fall arrest applications.



The system is suitable for fall arrest applications. Specify number of users. Max weight of 150kg.

- Always wear appropriate PPE when installing, setting up, dismantling and using this equipment.
- Misuse of this product could result in serious injury or death.

### Warning

- For fall protection applications the maximum user weight is 150kg or the weight allowed by the lowest rated piece of equipment in the fall arrest system
- Ensure that you have read and understood the maximum force tables for each anchor point on the corresponding davit selected to be used with the Porta Base. This varies (is reduced) as the Davit radius increases
- When using for fall protection, only use one fall arrest device with each pulley/sheave and make sure they never cross paths with each other
- When using the product in conjunction with another manufacturers fall protection products, ensure that you have read the instructions for use of those products to ensure their suitability and any restrictions for use. Only use approved brackets for the connection of winches and self retracting lifelines

- It is essential for safety that the product is withdrawn from use immediately and not be used again until confirmed in writing by a competent person should;
  1. Any doubt arises about its condition for safe use or;
  2. It has been used to arrest a fall
  3. It has been used for any other purpose, other than as a component of a personal fall protection system

### Compatible Davit and Fall Protection Force Ratings

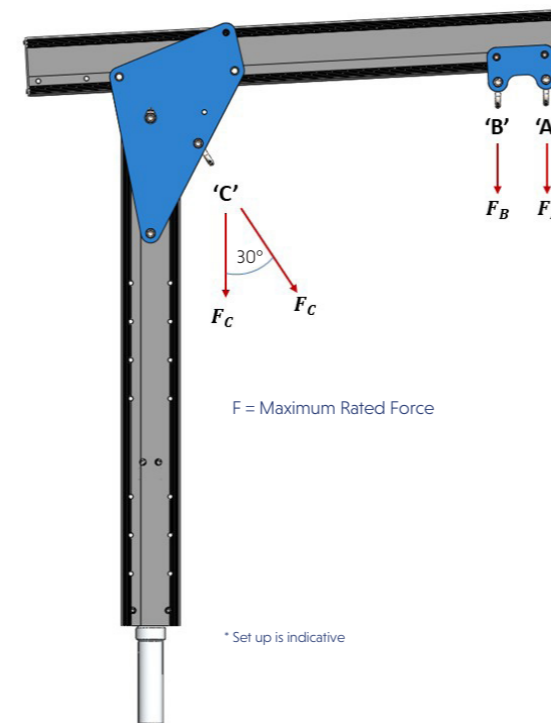

PFAS INFORMATION	T DAVIT [Type S]			
	Davit Radius	Anchor Point 'A'	Anchor Point 'B'	Anchor Point 'C'
Porta Base Trench Mount	800 mm	22.2 kN	22.2 kN	22.2 kN
	< 1000 mm	12 kN	12 kN	22.2 kN
	< 1200 mm	12 kN	12 kN	22.2 kN

Only Davits up to 1200mm radius can be used with the Portabase Trenchmount Socket

## Compatible Davit and Fall Protection Force Ratings

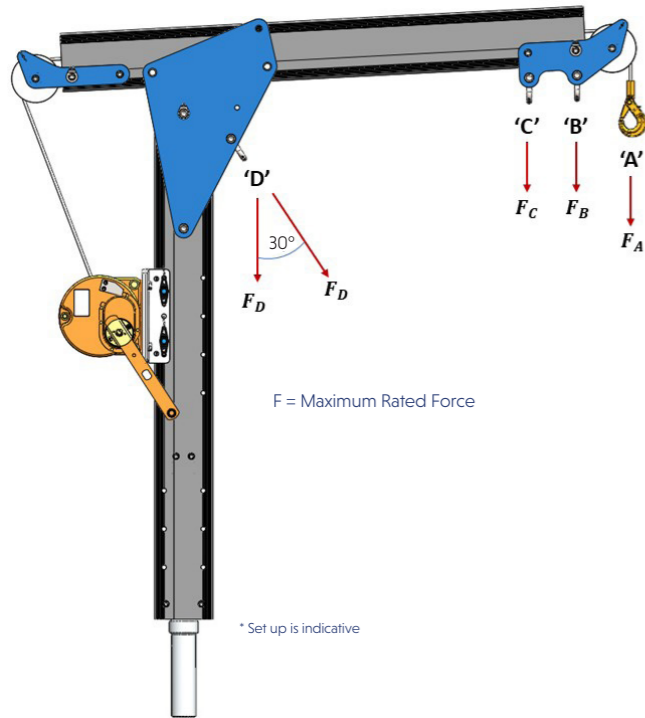

F = Maximum Rated Force

\* Set up is indicative

PFAS INFORMATION	T DAVIT [Type W]				
	Davit Radius	Anchor Point 'A'	Anchor Point 'B'	Anchor Point 'C'	Anchor Point 'D'
Porta Base Trench Mount	800 mm	22.2 kN	22.2 kN	22.2 kN	22.2 kN
	< 1000 mm	12 kN	12 kN	12 kN	22.2 kN
	< 1200 mm	12 kN	12 kN	12 kN	22.2 kN

Only Davits up to 1200mm radius can be used with the Portabase Trenchmount Socket

## Compatible Davit and Fall Protection Force Ratings

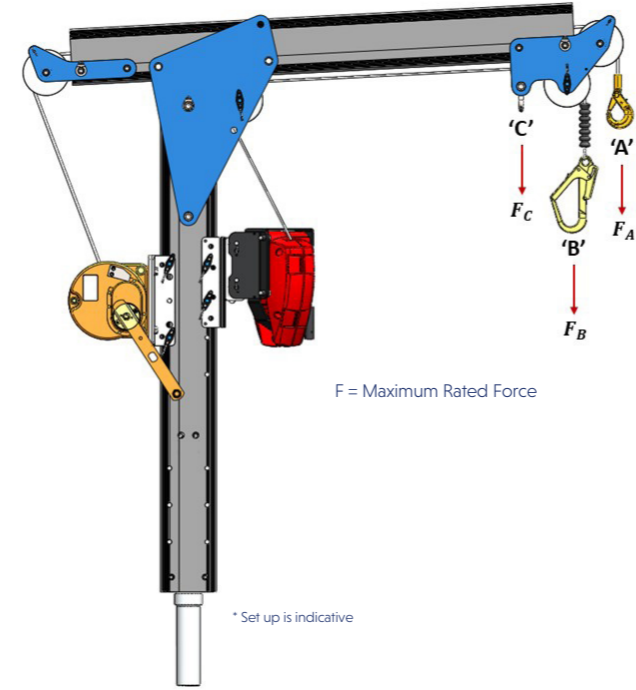

F = Maximum Rated Force

\* Set up is indicative

PFAS INFORMATION	T DAVIT [Type DW]			
	Davit Radius	Anchor Point 'A'	Anchor Point 'B'	Anchor Point 'C'
Porta Base Trench Mount	800 mm	22.2 kN	22.2 kN	22.2 kN
	< 1000 mm	12 kN	12 kN	12 kN
	< 1200 mm	12 kN	12 kN	12 kN

Only Davits up to 1200mm radius can be used with the Portabase Trenchmount Socket

The following information is based on REID Lifting's recommendations and does not remove the responsibility of the user to comply with the relevant regulations and standards that are valid in the respective countries and regions where the system is being used.

Before use, the product should be inspected for visual defects using the checklist below:

- › Ensure all welds on the system are free of cracks or defects
- › Ensure all bolts are correctly tightened and free from excessive corrosion
- › Ensure the king pin for the Davit is fully engaged in the hub before applying a load.
- › Check the Davit in accordance with its corresponding Assembly & Operation Guide.

Inspections are instigated by the user, the above list covers the main components on this product, any accessories and third-party components must be inspected following the corresponding instructions.

### Regular Inspections

To ensure that the product's frame remains in safe working order it must be inspected regularly by a competent or qualified person. We recommend inspections every 6 months for personnel lifting and every 12 months for goods only, unless local regulations, adverse working conditions or profile of use and risk dictate shorter periods.

The components of the system frame need to be checked for damage, wear, corrosion or other irregularities. It may be necessary to disassemble the system frame in order to do this. Particular attention should be paid to checking the profiles for denting, making sure there is no wear or elongation on the bolt holes and ensuring that the trolley moves freely along the beam.

It is recommended that once inspected or repaired, the device is marked with the date of the next inspection.

Inspections are instigated by the user. If detailed information is required on inspection and test criteria, please contact your supplier's technical department or REID Lifting.

### Maintenance & Repair

In order to ensure correct operation, the conditions for inspection and maintenance must be complied with. If any defects are found, stop using the product immediately.

No alterations or additions to the equipment beyond the replacement of standard parts by an authorised representative should be made without the written consent of the manufacturer. Any necessary repairs identified during inspections should only be carried out by an approved specialist workshop using original spare parts. Any repair must be carried out in accordance with the manufacturer's instructions.

It is recommended to maintain the equipment in a clean and dry manner. Cleaning is suggested using a sponge or cloth with warm, soapy water, rinsing and allowing to dry.

This product must be assembled using metric fixings of the same type and quality as those supplied by the original manufacturer only. Failure to do so could have an impact on the structural performance and stability of the product. Reid Lifting and its resellers can supply these spare parts locally.

### Storage & Transportation

When transporting the components, take note of all the manual handling considerations.

Do not throw the product down or stack any items on top of it.

Always place carefully and securely on the ground to avoid damaging the equipment.

When fitting the **PORTABASE** Trench Mount please observe the following points:

- › Lower the Trench Mount on to a suitable structure at the desired Location as shown in figure 1.
- › Tighten the fixing rods to approximately 20Nm on the front and the back of the Trench Mount as shown in figure 2. [A 36mm socket wrench or spanner will be required to tighten the fixing rods]. Ensure the Trench Mount is level by checking the bubble level included.
- › Lower the davit column into the Trench Mount and ensure it is seated properly. Continue the assembly of the davit as per the Assembly & Operation Guide [Figure 3].

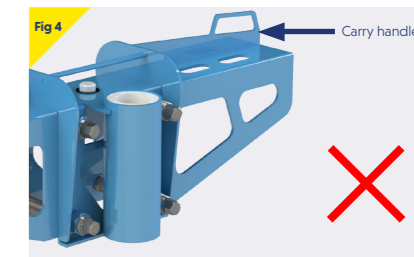
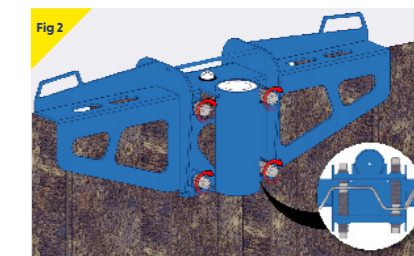
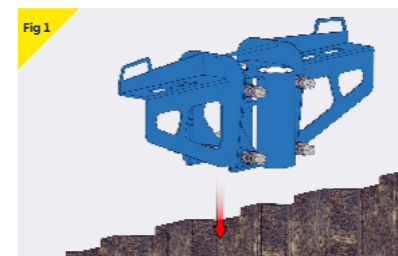

**Note:** The carry handle cannot be used as a fall protection anchor point.





## Regulations, Standards & Directives

This product complies with the following:

- › Machinery Directive 2006/42/EC
- › PPE Regulation (EU) 2016/425
- › The Provision and Use of Work Equipment Regulations 1998 (S.I. 1998 No. 2306)
- › The Lifting Operations and Lifting Equipment Regulations 1998 (S.I. 1998 No. 2307)
- › In conformity with EN795:2012 and OSHA 1926.502(d)(15)

It is essential to adhere to the safety regulations of the respective country for using manual lifting equipment.

## Accreditations

Quality and Safety are at the heart of the REID Lifting ethos and we are committed to maintaining the very highest standards. With this in mind, we have undertaken external accreditations to ensure we stay focused on what is important to our clients and users, and ahead of market trends and developments.

REID Lifting is continuously audited by Lloyds Register Quality Assurance (LRQA) for approval of its Integrated Management System combining quality systems management, environmental issues and the health and safety practices within the company.

- › ISO 9001:2015 - Quality management system which assesses an organization's ability to consistently provide products that meet customer and applicable regulatory requirements and aims to enhance customer satisfaction.
- › ISO 14001:2015 - Specifies the requirements for implementing environmental management systems throughout all areas of the organization.
- › ISO 45001 – Health & Safety Management System

- › LEAA Membership - REID Lifting is a full member of the Lifting Equipment Engineers Association (LEEA membership 000897). REID Lifting conforms to the main aims of the association which is to achieve the highest standards of quality and integrity in the operations of members. Entry qualifications are demanding and strictly enforced through technical audits based on the Technical Requirements for Members.
- › IRATA - REID Lifting is an associate member of the Industrial Rope Access Trade Association (IRATA International membership number 148). REID Lifting works in accordance with the IRATA Code of Practice and, in doing so, contributes to promote the development of safe systems.

## Conformité Européenne [CE] & UK Conformity Assessed [UKCA]

REID Lifting's products have been designed, tested and approved (as appropriate) by the Conformité Européenne and UK Conformity Assessed. This certifies that REID Lifting's products meet the demands of the European and UK Directives and Regulations regarding Health and Safety requirements. The EC type-examination for this device has been carried out by SGS United Kingdom Ltd, 202b, Worle Parkway, Weston-super-Mare, BS22 6WA, United Kingdom (CE body no.0120) in accordance with Module B of the PPE Regulation. The EC quality assurance system for this device has been carried out by SGS Fimko Oy, Takomotie 8, FI-00380 Helsinki, Finland. (CE body no. 0598) and SGS United Kingdom Ltd, 202b, Worle Parkway, Weston-super-Mare, BS22 6WA, United Kingdom (CE body no.0120) in accordance with Module D PPE Regulation (EU) 2016/425 and as brought into UK law and amended.

## The Queen's Award for Enterprise

REID Lifting has been awarded this prestigious award on four occasions for design, development and sale of lightweight, portable and safe lifting solutions.

- › Innovation category 2006 and 2013
- › International Trade 2013 and 2018

## Testing

Testing and technical file review are integral parts of our design and manufacturing process. External verification of products is undertaken where appropriate, using government approved Notified Bodies.

All products have been thoroughly type tested. Each product is supplied with a certificate of conformance and individual record of thorough examination or test.

## Language

It is essential for the safety of the user that if this product is re-sold outside of the original country of destination, the reseller shall provide instructions for use, maintenance, inspection and repair in the language of the country where it will be used.

## Product IPR

Intellectual property rights apply to all REID Lifting Ltd products. There are patents in place, or pending, for:

PORTAGANTRY™ | PORTAGANTRY<sup>RAPIDE</sup>™ | PORTADAVIT<sup>QUANTUM</sup>™ | TDAVIT™

All product names are trademarks of REID Lifting Ltd:

PORTAGANTRY™ | PORTAGANTRY<sup>RAPIDE</sup>™ | PORTADAVIT™ | PORTABASE™ | TDAVIT™ | PORTAQUAD™

## Safety Labels



Insert and secure the bolt before loading the system.



Insert the detent pin and fully engage before loading the system.



Insert the clevis pin and secure with the clip before loading the system.



Restraint point only.



Read the operational manuals before using the system.



Ensure the pin is fully engaged.

## Serial Labels

1. Product Number
2. Serial Number
3. WLL
4. Year of Manufacture
5. Standards
6. ATEX
7. Max Moment



The system is not suitable for fall arrest applications.



The system is suitable for fall arrest applications. Specify number of users. Max weight of 150kg.

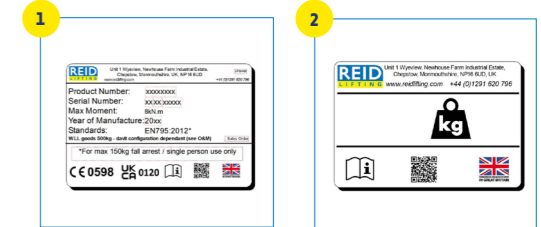
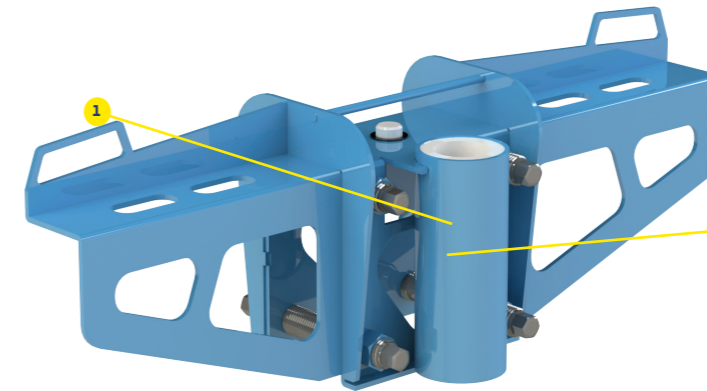





# Contact Us

## Head Office, UK

Unit 1 Wyeview  
Newhouse Farm Industrial Estate  
Chepstow  
Monmouthshire  
NP16 6UD  
United Kingdom

- > +44 (0)1291 620 796
- > [enquiries@reidlifting.com](mailto:enquiries@reidlifting.com)
- > [www.reidlifting.com](http://www.reidlifting.com)

All information herein is copyright protected by REID Lifting Ltd. All company and product names are Trade Mark and Trade Name protected and all REID Lifting Ltd. Product IPR is protected under Patents, Patents Pending and/or Design Rights.

 Printed using environment friendly processes and materials.